

# BATHROOM EQUIPMENT

MAGNIFYING MIRROR (X3) 2 ARMS ECLIPS  
ESPEJO AUMENTO (X3) 2 BRAZOS ECLIPS

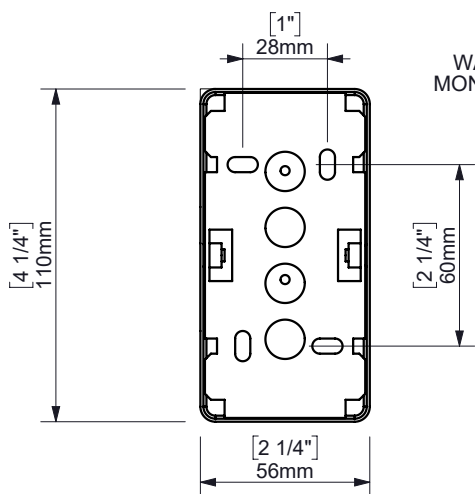

WALL FIXATION  
MONTAJE A PARED

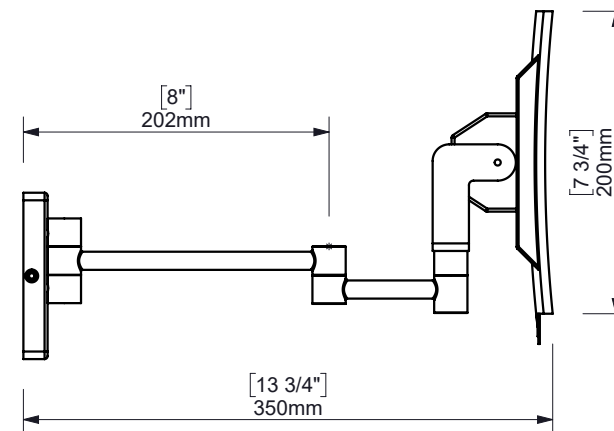
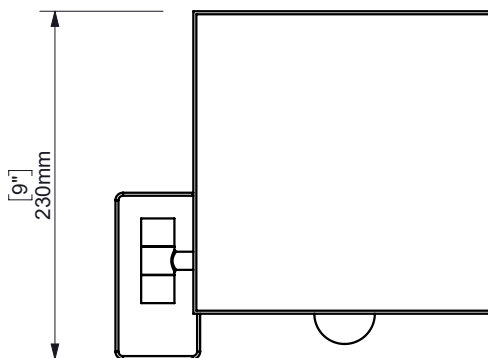
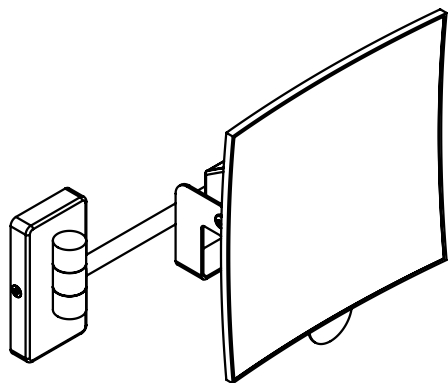
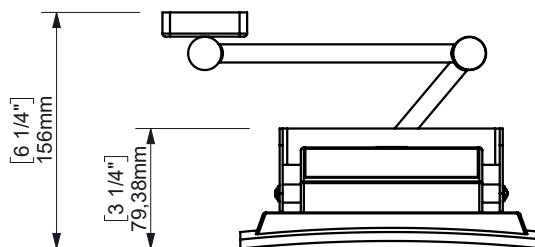

espec\_1082

Peso / Weight / Poids : 1,25 Kg.

Data / Datos / Données:

Normas / Regulations / Normes:

Imágenes no a escala / Draw not to scale / Echelle non respectée

Sonia S.A se reserva el derecho de realizar cualquier cambio sin previo aviso  
Sonia S.A has the right to make changes without notice  
Sonia S.A se réserve le droit de procéder à tout changement sans notification préalable



MADE IN EUROPE

www.sonia-sa.com